

Your Partner

MICROTEST  
SWISS MADE



## PRECISION-MEASUREMENT

Microtest AG Switzerland specializes in measurement of internal diameters for over 50 years. We offer efficient, economic and precise solutions for measurement of internal diameters which help improve your quality standards.

Through permanent optimisation, constant further development and improvement, our measuring instruments have reached a very high standard of precision, reliability and universality for the high requirements of our customers.

Our products are being used all over the world and guarantee the highest precision over long period of time. Our robust instruments are suitable even for the rough environment of the production plants as well as for the measurement and test laboratories. MICROTEST® supports many sectors of the industry, like Machine, Tool, Gear, Motor, Engine, Pump, Compressor, Vehicle, Train, Turbine and Power Station construction as well as in Oil-Field-, Mining-, Aviation- and Aerospace-Technology.

**Supported sectors of the industry:** Machines, Tools, Pumps, Compressors, Train, Vehicle, Gear, Motor, Engine and Turbine production.

**Supported technologies:** Oil-Field, Power plant, Earth-Move, Mining, Aviation and Space.



## THE WORLD'S LARGEST 3-POINT INTERNAL MICROMETER

The new MICROTEST® internal thread measuring system is the first which succeeded in combining a high accuracy of measurement with a multiple measuring range.

Microtest internal micrometers are manufactured in 6 different ranges from  $\varnothing$  30 mm to  $\varnothing$  400 mm and in three special instruments from  $\varnothing$  400 mm to  $\varnothing$  1150 mm. Our instruments are also able to measure blind-holes down to the ground and diameter in deep cylinders up to 7.5 m within a few microns. Due to consequent thermal insulation and compensation the Microtest system is qualified especially for the rough environment of the production plants as well as for the quality controlling.

[www.microtest.ch](http://www.microtest.ch)

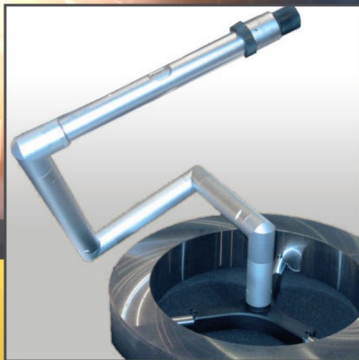

**MICROTEST**  
SWISS MADE



### Ring Gauges

(in accordance with DIN 2250)

Further to our range of products, we also offer high-precision, lapped calibration rings for highest requirements. We provide different sizes upon request.

### Elbow and extension

For micrometer till  $\varnothing$  400 mm, available extensions are 50, 100, 200, 350, 500, 750, 1000 and 1500 mm.

### The New: Microtest-Tripod

It supports the internal micrometer with extension to achieve an optimal pre-centring in the bore hole. From 2 meter extensions onward it is recommended to use our new Microtest-Tripod after 2/3 of length, similar to Bessel's rule.

### Available Tripod Sizes:

$\varnothing$  60-90,  $\varnothing$  90-140,  $\varnothing$  140-240, and  $\varnothing$  240-400 mm.

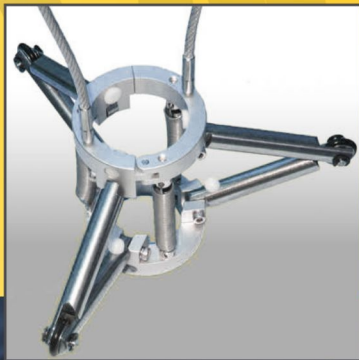

### Service and Maintenance

Our precision measuring instruments require no servicing.

#### Overhauling

Overhaul is only due after between 7 and 15 years. When your instrument is returned it measures as accurately as a new one.

#### Calibration

All the measuring instruments and gauges that we supply are uniquely identifiable through a unique device number and are examined, calibrated and certified.



### Microtest AG - Precision Instruments

Sihleggstrasse 23, CH-8832, Wollerau, Switzerland  
Tel.: +41 (0)44 723 12 76, Fax: +41 (0)44 723 12 71  
E-Mail: [info@microtest.ch](mailto:info@microtest.ch), Web: [www.microtest.ch](http://www.microtest.ch)

